

5330 East 25th Street
Indianapolis Indiana 46218
Phone: (888) 445-4142

Emergency Eye Wash Assembly With Valve

Used with the
following
assemblies

T2210
T2215
T2230
T2235
T2510
T2515
T2530
T2535

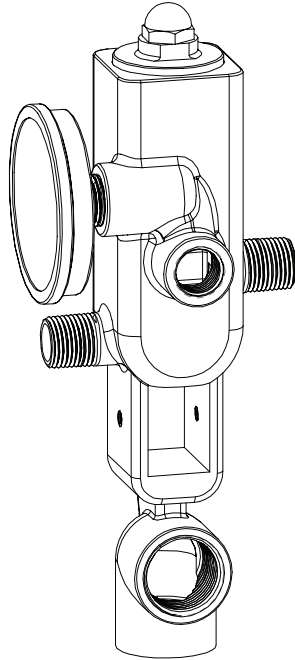

 **ASSE 1071 Certified**

Note: Gallon per minute ratings may vary depending upon incoming water temperatures and pressures. Hot and cold water inlet pressures must be equal.

Provisions shall be made to thermally isolate the valve.

Setting the Mixing Valve

Caution: When maintaining and adjusting the mixing valve, all fixtures should be isolated from use. Stingray Systems recommends that you work safely at all times and in a manner consistent with the OSHA Lock/Tagout standard, 29 CFR 1910.147 and other applicable standards.

This mixing valve has been set at the factory to deliver 85°F outlet flow. Should the valve require adjustment, or an application require a different set temperature, proceed as follows:

1. Contact the proper medical and safety authorities to determine the correct water temperature for the specific application (ie. chemicals).
2. Remove the rounded cover nut on top of the cartridge body.
3. Create a draw on the mixing valve by opening the downstream eye wash fixture.
4. Insert a $\frac{5}{32}$ " allen key into the stem opening of the valve and seat in the adjustment screw (not shown). Set the outlet temperature by turning the adjustment screw clockwise to reduce temperature, counterclockwise to increase temperature. Use the dial thermometer to measure the outlet temperature.
5. Replace rounded cover nut.

CAPACITIES – TIV-107

Pressure Drop PSI	5	10	20	30	45
Tempered Flow	2	3	5	7	10
Cold Water Bypass	1	2	4	5	7

Operating Principle

This TIV-107 Emergency Eye Wash/Face Wash mixing valve is made of a thermostat element with a stainless steel sliding piston and liner housed in a bronze casting. The thermostatic cartridge responds to temperature changes in the hot and cold water supplies. In the event the thermostatic element fails or the hot water supply fails, the valve will provide full cold water bypass flow.

Note: Valve must be installed with check valves. If shut off valves are installed in the shower line for maintenance purposes, provisions shall be made to prevent unauthorized shut off.

Testing the Mixing Valve

The integrated mixing valve and emergency fixture should be tested weekly for proper operation.

Valve temperature test procedure is as follows:

1. Activate eye wash fixture to observe and record the temperature of the dial thermometer. If the temperature of the thermometer is not correct, readjust the mixing valve according to the section "Setting the Mixing Valve".
2. Observe the flow from the eye wash block to ensure an adequate flow of water.

In addition to testing for proper temperature, the cold water by-pass and hot water shut down features of the mixing valve should be tested weekly.

The test procedure is as follows:

1. Test valve temperature as described in Step 1 and Step 2 above.
2. Shut off the hot water supply to the mixing valve. Observe the outlet flow from the eye wash block to ensure an adequate flow of cold water. A slight drop in flow may occur after shutting down the hot water supply to the mixing valve; however, the drop should be minimal and for a short duration.
3. Open the hot water supply to the mixing valve. The thermometer should return to the set temperature.
4. Shut off the cold water supply to the mixing valve. The flow of water should shut down rapidly.
5. Open the cold water supply. The thermometer should return to the set temperature.

Note: The thermometer should be checked at least every six months.

Replacing the Thermostat Cartridge

The thermostat replacement procedure is as follows:

Note: Stingray Systems, Inc. recommends that you work safely at all times and in a manner consistent with the OSHA Lock/Tagout standard, 29 CFR 1910.147 and other applicable standards.

1. Shut off the hot water supply and cold water supply to the mixing valve.
2. Unscrew valve cartridge and install a new cartridge assembly.
3. Open the hot water supply and the cold water supply to mixing valve. Check the temperature to see if the replacement cartridge is operating correctly. If the temperature requires adjustment refer to the section "Setting the Mixing Valve."

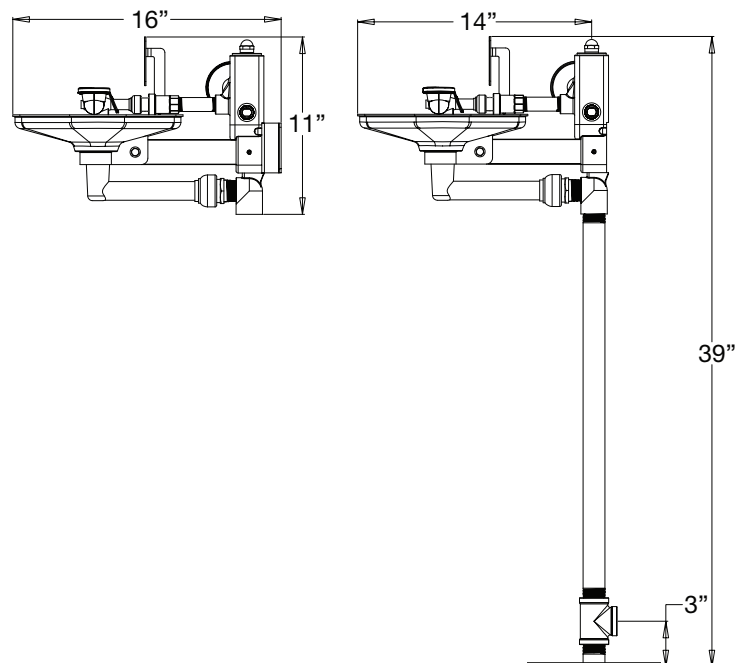
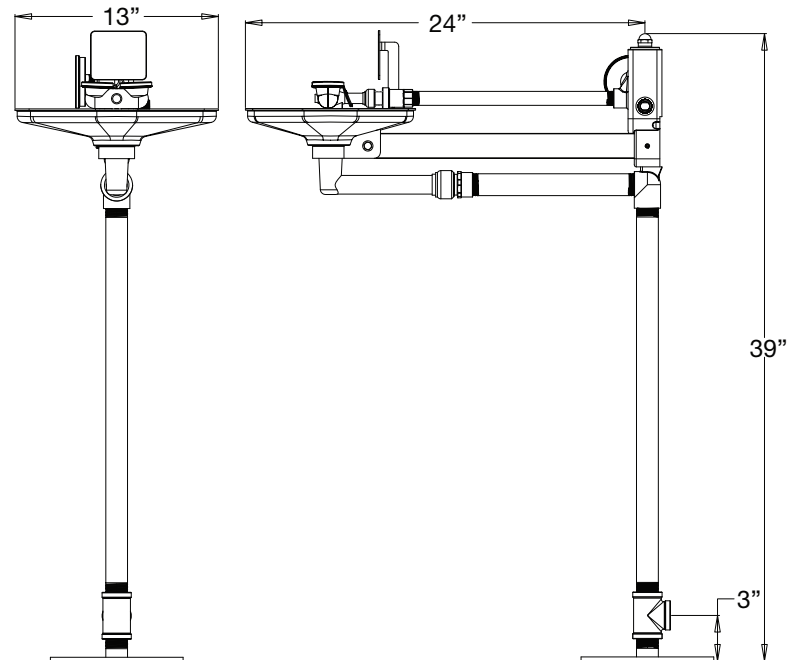
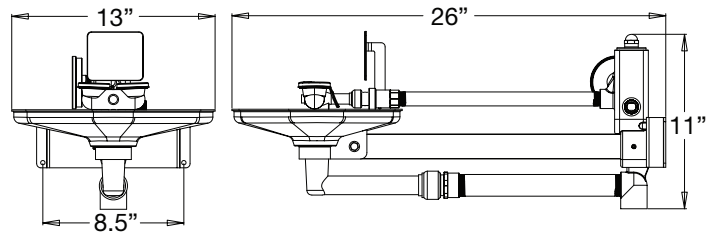

Installing the Fixture

- [WALL MOUNT] Attach TIV-107 Valve Assembly to Wall Mount Plate and Secure Wall Plate to wall with wall anchors (anchors not included).
- [PEDESTAL MOUNT] Secure base plate to floor and thread section of pipe to base and TIV-107.
- Insert Eye/Face Wash Bowl Assembly into Manifold with red drainpipe going into drain fitting. Tighten setscrews on side of Manifold to support tube. Press fit drain fitting on Manifold Assembly to red drainpipe on Eye/Face Wash Bowl Assembly. See figure 1
- Flush system of any debris prior to installing eye-block
- Loop Eye Piece Safety covers to Eye Block inlet tube on Eye Block Assembly. Press fit Eye Block into Eye/Face Wash Bowl Assembly. See figure 2
- Mount sign near the assembled unit at the desired location.
- Connect 1/2" hot water supply to hot water inlet and 1/2" cold water supply to cold-water inlet on the assembled station. Installer to provide sufficient support of piping so that the assembled station is not relied on to supply support.
- Connect 1" drain piping to drain outlet at the bottom of the station.
- Open supply line to check for leaks. Push on activator to insure adequate flow and drainage through Eye/Face Wash. Pull back to stop water flow.

Maximum Inlet Pressure: 125 PSI.

Minimum Flow Rate: 1.5 GPM.*

Recommended Supply Pressure: 65 PSI.

Recommended Inlet Temperature: 120°F.**

* Installer shall verify that no single emergency fixture supplied by this device has a minimum flow rate less than 1.5 GPM

** When supplying 140°F or greater, additional outlet controls should be used.

Additional information is available at tepid.com

Figure 1
Installation of Eye/Face wash Bowl Assembly

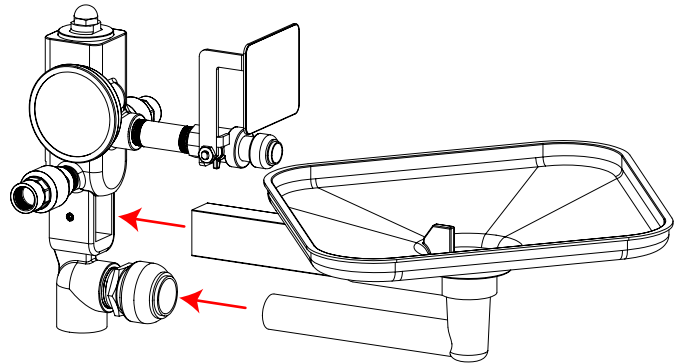
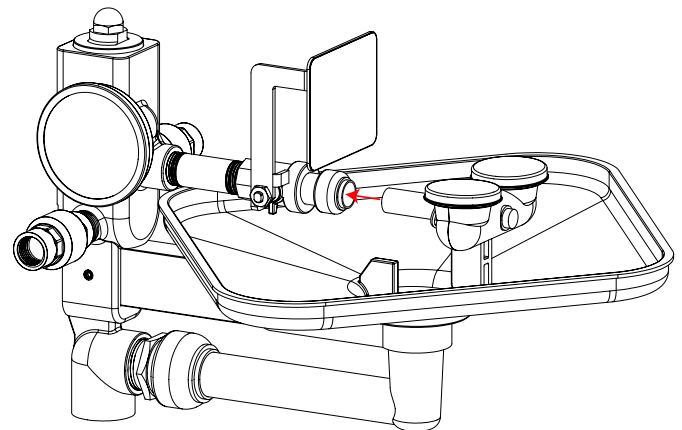

Figure 2
Installation of Quick Switch Eye/Face Wash Element



Caution: When maintaining and adjusting the mixing valve, the delivered flushing fluid temperature shall be 60°F (15°C) to 95°F (35°C). In circumstances where chemical reaction is accelerated by flushing fluid temperature, a medical advisor should be consulted for the optimum temperature for each application.

Warning: This product contains chemicals known to the State of California to cause cancer and birth defects or other reproductive harm.
(Installer: California law requires that this warning be given to the consumer.)
 For more information: www.oehha.org/prop65

Caution: The cold water line must be installed so that it is not affected by excessively hot ambient temperatures. Provisions shall be made to thermally isolate the valve. Cold water pipe installed in the ceilings of boiler rooms or rooms that increase ambient temperature require a recirculating pump.

Note: The valve body must be maintained at an ambient room temperature of above 50°F to prevent premature closure of the safety back-seat mechanism.

Parts Break Down For TIV-107

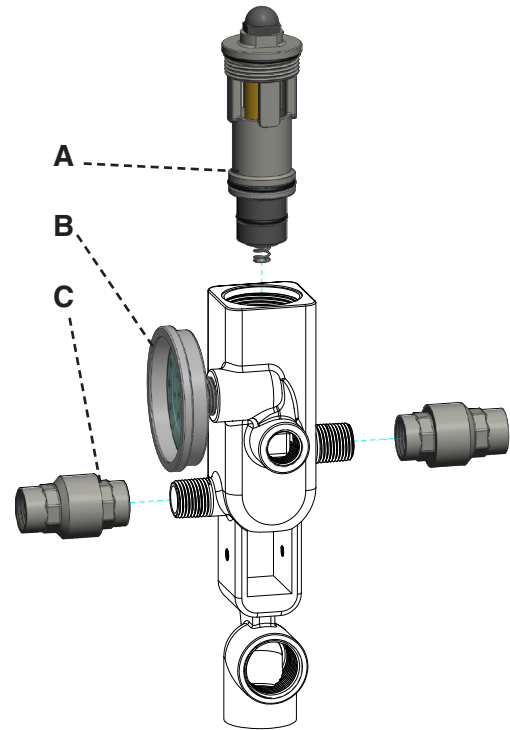

Repair Kits and Assemblies

Item	Description	Part No.
A	TIV-107 Cartridge	008490861
B	Thermometer	000667902
C	1/2" ENP Check Valves (Pair)	000844580



Standard ABS Bowl with Drain Tube	000887362
Standard Stainless Steel Bowl Assembly	008780052
Barrier Free Stainless Steel Bowl Assembly	008780053
5 GPM Filtered Quick Switch Eye/Face Wash Element	008781057
5 GPM Non-Filtered Quick Switch Eye/Face Wash Element	008781052
2 GPM Filtered Quick Switch Eye Wash Element	008781027
2 GPM Non-Filtered Quick Switch Eye Wash Element	008781022

GUARANTEE

We guarantee the Stingray Systems Mixing Valve to be free from defects in workmanship and material, and for a period of eighteen (18) months from date of shipment from the factory or one (1) year from date of installation, whichever occurs first, will replace any parts found by us to be defective. We will not be held responsible, however, for any labor incidental to, or for any damages caused by defective material. Each mixing valve is thoroughly inspected and tested under actual conditions at our factory.