



5330 East 25th Street  
Indianapolis Indiana 46218  
(888) 445-4142  
www.tepid.com

ANSI/ISEA Z358.1 Certified  
Patent Information:  
tepid.com/patents

## Stingray Systems **S2210/S2215** Floor Mounted Eyewash

The S2210/S2215 emergency eyewash is a floor mounted unit that shall be manufactured of corrosion resistant materials. The manifold assembly shall be a nickel-plated brass unit with 1" NPT female connections for inlet and drain piping. It shall include a centrally located activator with universal ANSI compliant sign.

The bowl assembly shall include a First Aid Red ABS bowl (or stainless steel bowl). The spray heads shall be PVC with dust caps and designed to flow at the specified flow rate. The spray heads shall be incorporated into a Quick Switch Eyewash Block that can be easily removed and serviced, allowing the supply piping to be flushed. The Quick Switch Eyewash Block (with optional integral point of use filters) shall be a single supply source eyewash unit to ensure symmetrical and equal flow through each spray head. The eyewash will come complete with nickel-plated inlet pipe.

The unit shall incorporate a 1/4" thick base plate that is 8" in diameter and shall be secured to the floor with appropriate anchors. The standpipe shall be galvanized steel (or epoxy coated or stainless steel) and will serve as the drainpipe to take water away from the unit. It shall be at the correct length to get the spray heads to the correct elevation per ANSI/ISEA Z358.1. The eyewash shall be installed level and be self-draining to hinder bacteria growth. The eyewash shall also be independently certified to meet the latest ANSI/ISEA Z358.1 requirements.

As an eyewash, this unit will have a regulated flow rate of less than 3 gpm measured at 30 psi.



**Series: S2210/S2215**

**Model Number:**

- S2210 Floor Mounted Standard Eyewash
- S2215 Floor Mounted Barrier-Free Eyewash

**Pipe Finish:**

- Galvanized (**GA**)
- Epoxy Coated (**EP**)
- Stainless Steel (**SS**)

**Quick Switch Eyewash Block Options:**

- Filter (**FLT**)
- No Filter (**NFT**)

**Bowl Material Options:**

- ABS (**AB/NA**)
- Stainless Steel (**SS/NA**)

For a complete **TEPID** solution, this fixture shall be combined with a Stingray SV107 emergency mixing valve.



5330 East 25th Street  
Indianapolis Indiana 46218  
(888) 445-4142  
www.tepid.com

ANSI/ISEA Z358.1 Certified  
Patent Information:  
tepid.com/patents

**Model: S2210**

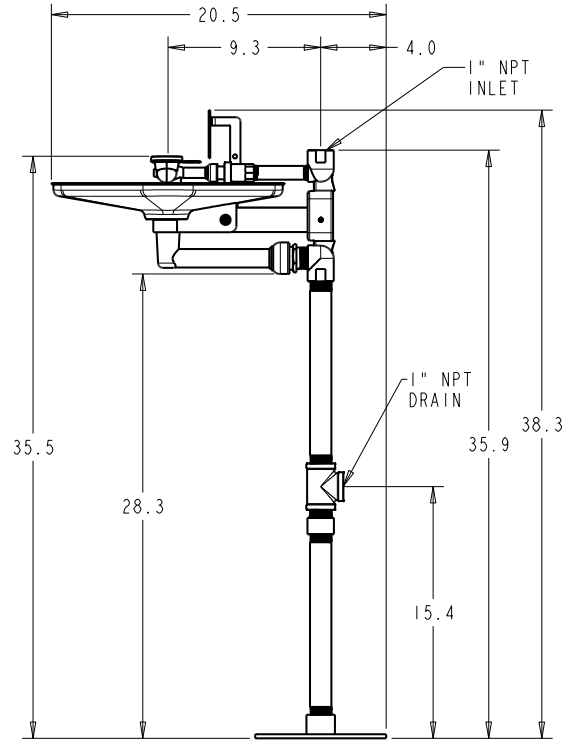
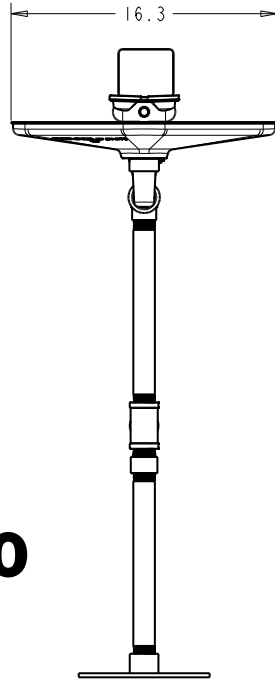

**Model: S2215**

